

# SCORPION 12"

Android Rugged Tablet PC

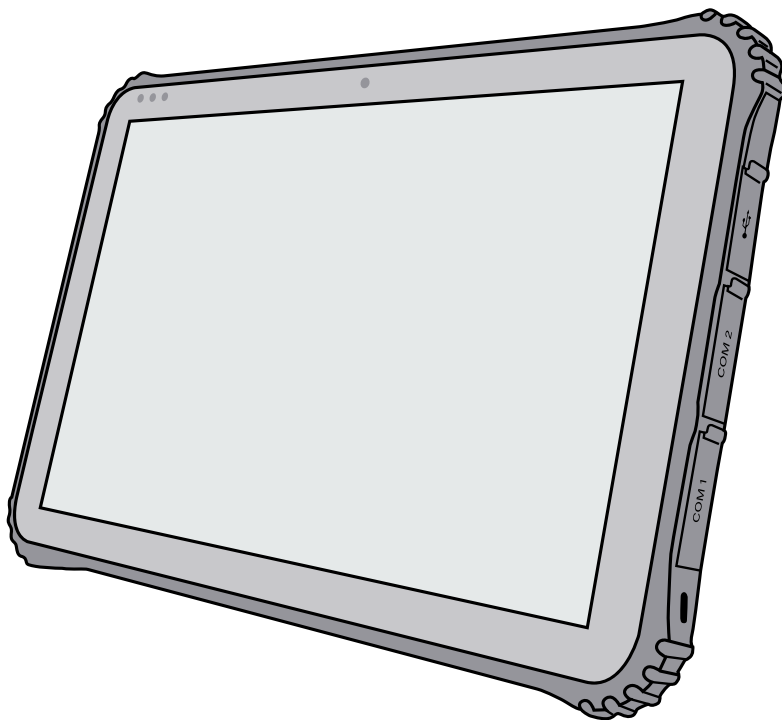

For more information about the product and a detailed description, please visit:

<https://www.scorpion-rugged.de/en/12-models/scorpion-12-android/>

**BRESSNER Technology GmbH**

Industriestrasse 51  
82194 Grobenzell

Phone: +49 (0) 8142 47284-76

E-mail: [scorpion@bressner.de](mailto:scorpion@bressner.de)

# SCOPE OF DELIVERY

## This package includes:

1. SCORPION 12" - Android Rugged Tablet
2. 5V/4A power adapter with 2-pol EU cable and barrel connector 3,4 / 1,4mm
3. USB OTG cable (USB-C male to USB-A female)
4. USB charging cable (USB-C male to USB-A male)
5. Foldable stand (incl. screws)
6. Carrying strap
7. Plastic lever
8. Hand strap



# FEATURES

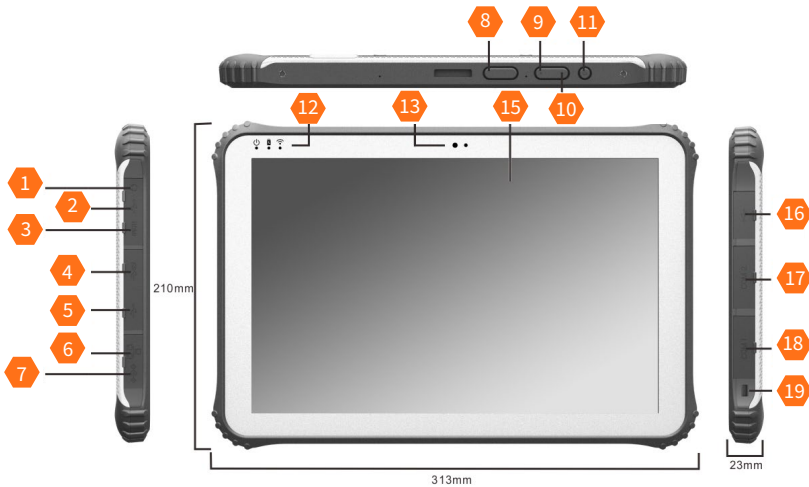

COM 2	
Pin	RS-485
1	B
2	A
3	NC
4	NC
5	A-GND
6	NC
7	NC
8	NC
9	NC

## Features:

1. Audio-Out 3,5mm
2. USB Type C
3. Mini-HDMI (HDMI 1.4a Type C)
4. USB 3.0
5. USB 2.0
6. LAN
7. DC input
8. Buttons P1/P2
9. Volume +
10. Volume -
11. Power On/Off
12. Status LEDs: (power/charge indicator/WLAN)
13. 2MP front camera
14. Docking port
15. Corning® Gorilla® Glass
16. USB 2.0
17. DB-9 serial COM 2: RS-485 fixed (Pin1: D+ / Pin2: D- / Pin5: GND)
18. DB-9 serial COM 1: RS-232 fixed (standard)
19. Kensington lock
20. Replaceable battery (SIM and SD card slots are located below the battery)
21. 5MP rear camera
22. Barcode scanner (optional)
23. Scan button F
24. Right speaker
25. Left speaker

A = Treiber Output / Receiver Output, Non-Inverting (D-)  
B = Treiber Output / Receiver Output, Non-Inverting (D+)

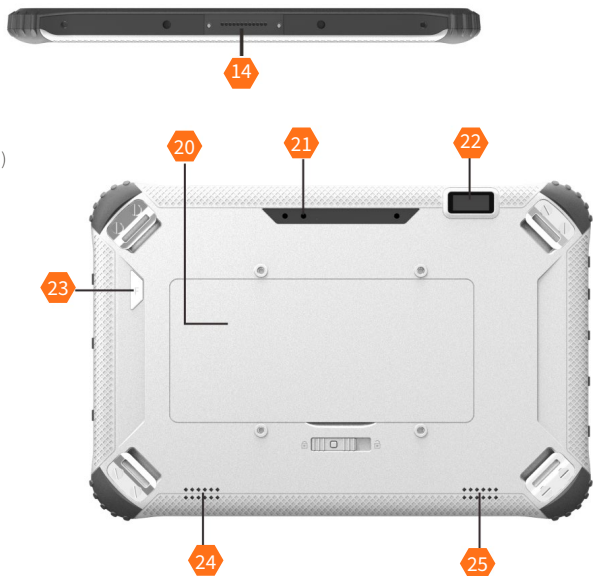

# BATTERY REMOVAL

Please follow the instructions, when removing battery!

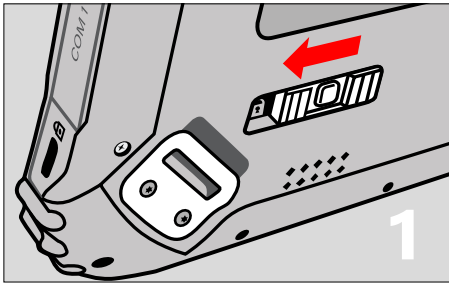

## Step 1

First release the battery cover lock by moving the slider on the back of the tablet to the left.

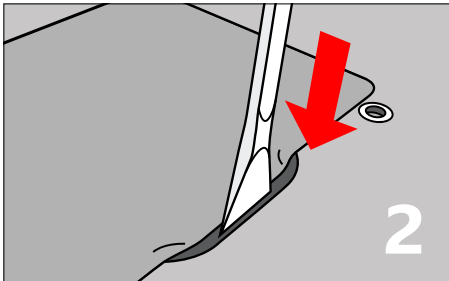

## Step 2

Take the enclosed plastic lever and carefully lift the battery out of the battery compartment (see illustration).

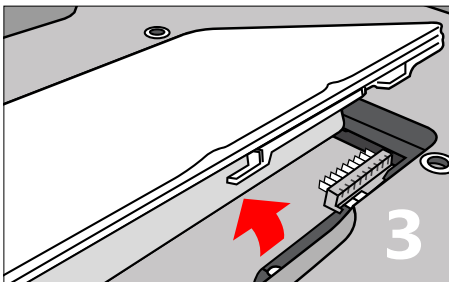

## Step 3

Carefully lift out the battery, insert a replacement battery, and reverse the steps to close and reseal the tablet.

## How to insert the SIM card correctly:

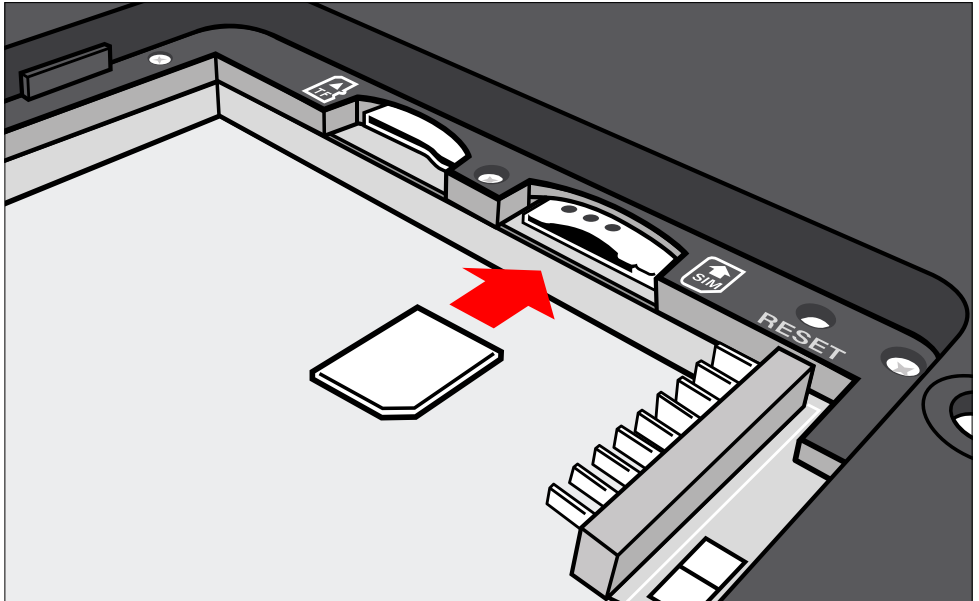

In order to reach the SIM card slot the device's battery must be removed first (please follow the instructions on the left side). After removing the battery, insert the micro SIM card into its designated slot (see illustration), until it locks in. Please make sure that the gold contacts of the SIM card are on the bottom side. Afterwards repeat step 1 to 3 on the left side in reverse order to reseal the device properly.

# SCANNER SETUP

## Honeywell 2D scanner N3680 (optional)

### Technical Details

The N3680 barcode scan engine is a revolutionary, fully decoded, compact 2D imager from Honeywell. It inherits the legendary Adaptus™ 6.0 decoding performance in our most compact design. The N3680 2D imager represents a fine balance between size, performance and ease of integration – ensuring an excellent end-user experience.

Not only does the N3680 2D imager support a wide variety of symbologies, including 1D, 2D and PDF417 barcodes, it also includes advanced features that support reading poorly printed barcodes and can even read barcodes directly from smartphone screens. This makes the N3680 2D imager a perfect choice for reading mobile coupons and loyalty cards, mobile ticketing, paperless boarding passes and barcode payment systems for mobile wallet applications.

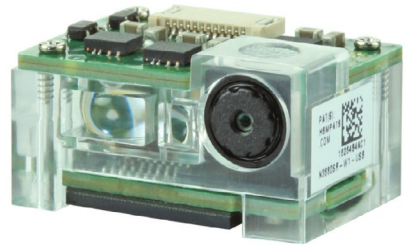

### Operation and configuration of the scanner

The user manual for the Honeywell scanner series N36XX provides a lot of information about the functionality and configuration of the scanner module. Use the included programming codes to transfer the desired configuration settings to the scanner. These programming codes can be scanned directly from the User's Guide. To do this, follow the instructions in each chapter. At the end of the manual you will also find a "Programming Chart" with the numbers 0-9 to be able to scan sequences of numbers if required. Attention - The configuration data is stored directly in the scanner module and not in the operating system. Consequently, you can use this type of scanner programming regardless of the installed operating system.

Examples of typical configuration settings:

Setting the language of the keyboard layout, activating/deactivating code types, configuring prefixes and suffixes, activating inverse codes, adjusting the position and size of the scanned section, loading factory defaults, etc.

### HardDecodeScan for Android

The SCORPION 12" - Android includes the pre-installed "HardDecodeScan" scanner app, which allows you to configure the most common scanner settings. Please use "HardDecodeScan" to set up specific functions, including enabling/disabling code types/symbologies, adding prefix/suffix, activating EnterSuffix, and more. When you **first launch the app, please make sure to select the "Honeywell two dimensional" scan module.**

If you still need assistance with setting up the scanner, please contact our support: **+49 8142 47284 - 44**



#### Datasheet

<http://bit.ly/n3680-datasheet-en>



#### User's Guide

<http://bit.ly/n36xx-user-guide-rev-b>

## Frequently asked questions

### **What should I do if the device or the scope of delivery does not meet my order or if individual components / accessories are missing?**

If you find that your order is incomplete or even faulty, our in-house support department will gladly attend to you. If you need help or assistance, please fill out the support form on our website to open a support case:

<https://www.bressner.de/en/support-en/>

Alternatively, you can send your request via e-mail: [ipcsupport@bressner.de](mailto:ipcsupport@bressner.de)

You can also contact our technical support on weekdays from 8AM - 5PM by phone: **+49 8142 47284 - 44**

### **What do I do if the device or individual components / accessories are defective?**

In case of a defect in equipment, individual components or the accessories supplied, a return shipment or repair can be arranged. BRESSNER Technology provides its own RMA form for this purpose. Please read the instructions on our website regarding the RMA procedure carefully before filling out the form and returning it.

You can find the form on our website at: <https://www.bressner.de/en/rma/>

You can also contact our RMA department on weekdays from 8AM - 5PM by phone: **+49 8142 47284 - 24**

# SAFETY INSTRUCTIONS

## Please read and observe carefully before using!



### Environment:

Protect the device from temperatures outside the specified range. The device is protected against spray water but must not be submerged in water or be exposed to water jets. Do not expose the unit to strong magnetic fields or strong static electricity. Once water or liquid has entered the unit, turn it off and do not use until it is dried. Have it checked by a qualified specialist.



### Safety in operation:

Do not drop the device. Do not bend or twist it. This may result in a breakage of the display glass or of circuit boards and mechanical parts. To avoid hearing damage, listen to music via headphones at a moderate volume and never place the speaker outputs directly in front of your ear. Keep packaging materials and small parts away from children. There is a danger of suffocation. Never open the case of the appliance or the charger (risk of electric shock, short-circuit and fire). Do not put objects through slots or openings on the appliance or charger (risk of electric shock, short circuit, and fire). Do not attempt to open the unit, the unit may be destroyed and you will lose warranty.



### Cleaning:

Never clean the surface of the appliance with solvents, detergents or other chemical products. Use a soft, dry cloth instead.



### Power supply:

Always use the original charger or one with suitable current and voltage rating to prevent damage to the device. If you use an universal charger, consider the polarity of the charger as well as the current and the voltage rating. Do not unplug the charger from the wall outlet by pulling the cable. Do not use chargers with damaged cables or plugs.



### Disposal:

Dispose used electronic equipment at the appropriate collection points. Please note that your device has a battery and therefore it must not be disposed with normal household waste. Please consult your local or municipal authorities for the correct disposal route of your device and battery.



### Battery:

Your device is designed for mobile use, which involves regular charging and discharging cycles. The current battery charging setting is not intended for continuous 24/7 operation. Continuous 24/7 charging without adjusting firmware parameters is not recommended, as it may increase the risk of battery swelling. A shortened warranty period of 6 months applies to rechargeable batteries.

Please also note the following:

- Fully charge the battery every six months
- Avoid exposing the device or the battery to excessive heat
- Do not expose the battery to mechanical stress
- Do not damage batteries with sharp or pointed objects
- Do not throw batteries into fire - they may explode
- Do not pour any liquids over the battery
- Avoid short-circuiting the battery, as it may result in overheating and ignition of the battery
- If liquid leaks from the battery and comes into contact with the eyes or skin, rinse immediately with clear water and seek medical advice
- Incorrect replacement of the battery may result in a risk of explosion
- Replace battery only by the same or an equivalent type recommended by the manufacturer
- Please do not dispose used batteries with household waste. Use the service of specialist shops that carry out the exchange.